



一般仕様 General Specifications

- ◇ モータ構造 : くまどりコイル型インダクションモータ
  - ◇ モータ保護 : インピーダンスプロテクト
  - ◇ 絶縁抵抗 : DC500V メガにて 100M Ω 以上
  - ◇ 絶縁耐圧 : AC1800V 3s
  - ◇ 許容環境温度範囲 : -10℃ ~ +70℃ (Operating)  
-40℃ ~ +70℃ (Storage)
- 実用上さしつかえない状態で結露無きこと

- ◇ Motor Structure : Shaded Pole Induction Motor
- ◇ Motor Protection : Impedance Protect
- ◇ Insulation Resistance : 100M Ω or over with a DC500V Megger
- ◇ Dielectric Withstand Voltage : AC1800V 3s
- ◇ Allowable Ambient Temperature Range :  
-10℃ ~ +70℃ (Operating)  
-40℃ ~ +70℃ (Storage)  
No such condensation as hinders practical use

期待できる寿命

Expected Life

- ※故障率 10%  
25℃ 50,000 時間
- ※ Failure rate 10%  
25℃ 50,000 hours

材質 Material

- ケーシング : アルミニウム
- インペラー : ポリカーボネート(ガラス繊維入り)
- 軸受 : ボールベアリング
- 端子 : ファストン #110 相当品
- Casing : Aluminum
- Impeller : Polycarbonate (Glass Fiber-Containing)
- Bearing : Ball Bearings
- Terminal : Faston #110 or Equiv

外観図 Outline

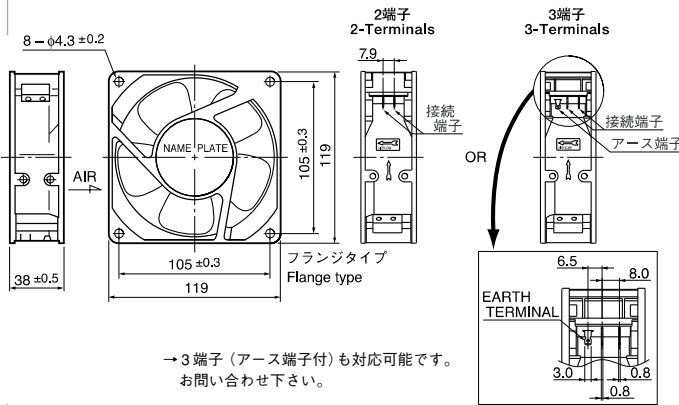

取付穴参考寸法 Panel Out-cuts

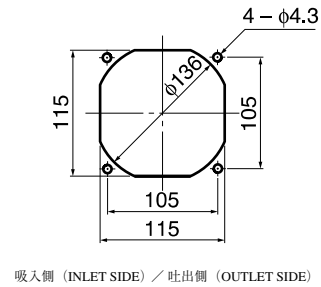

特性曲線 Characteristic Curves

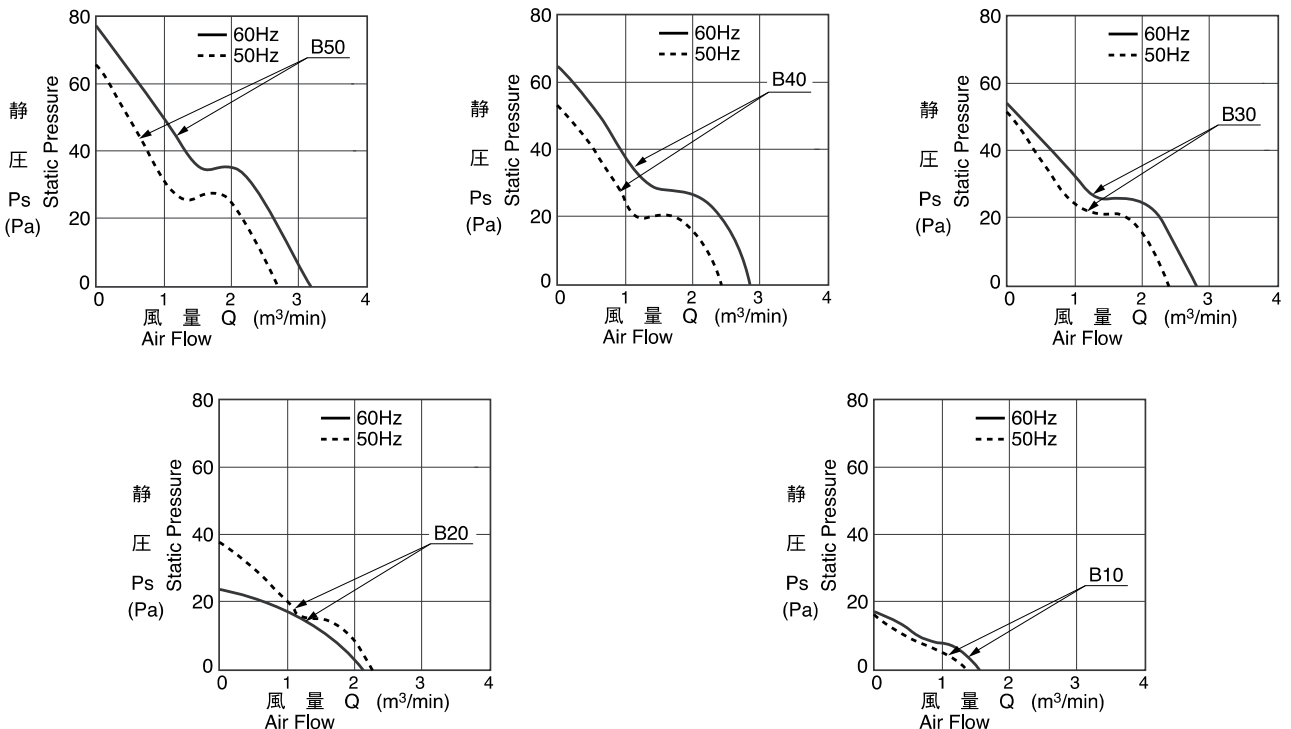

2端子タイプ、定格電圧 200V 以上には、アースタップがついています。



●仕様 Specifications

eMINEBEA.COM

**B50 型スタンダードタイプ Standard Type B50**

型式 Model	定格電圧 Rating Voltage	周波数 Frequency	起動電圧 Starting Voltage	定格電流 Current	定格入力 Input Power	定格回転速度 Speed	最大風量 Max. Air Flow	最大静圧 Max. Static Pressure	騒音 Noise	質量 Mass
	(V)	(Hz)	(V)	(A) <sup>*1</sup>	(W) +10%, -20%	(min <sup>-1</sup> ) <sup>*3</sup>	(m <sup>3</sup> /min) <sup>*3</sup>	(Pa) <sup>*3</sup>	(dB) <sup>*2</sup>	(g)
4715MS-10T-B50-B00	100	50	65	0.270	15.0	2600	2.50	64.6	37	550
		60		0.230	14.0	2900	2.90	76.4	41	
4715MS-12T-B50-A00	115	50	65	0.250	15.5	2600	2.50	64.6	37	
		60		0.210	14.5	2900	2.90	76.4	41	
4715MS-20T-B50-B00	200	50	130	0.140	15.0	2600	2.50	64.6	37	
		60		0.120	13.0	2900	2.90	76.4	41	
4715MS-22T-B50-B00	220	50	145	0.120	14.0	2600	2.50	63.7	37	
		60		0.100	13.0	2900	2.90	75.4	41	
4715MS-23T-B50-A00	230	50	175	0.120	15.0	2600	2.50	63.7	37	
		60		0.100	14.0	2900	2.90	70.5	41	
4715MS-24T-B50-A00	240	50	140	0.110	14.0	2600	2.50	63.7	37	
		60		0.100	13.0	2900	2.90	65.6	41	

**B40 型スタンダードタイプ Standard Type B40**

型式 Model	定格電圧 Rating Voltage	周波数 Frequency	起動電圧 Starting Voltage	定格電流 Current	定格入力 Input Power	定格回転速度 Speed	最大風量 Max. Air Flow	最大静圧 Max. Static Pressure	騒音 Noise	質量 Mass
	(V)	(Hz)	(V)	(A) <sup>*1</sup>	(W) +10%, -20%	(min <sup>-1</sup> ) <sup>*3</sup>	(m <sup>3</sup> /min) <sup>*3</sup>	(Pa) <sup>*3</sup>	(dB) <sup>*2</sup>	(g)
4715MS-10T-B40-B00	100	50	65	0.250	15.0	2450	2.40	50.9	35	550
		60		0.220	13.0	2750	2.70	62.7	39	
4715MS-12T-B40-A00	115	50	75	0.220	15.0	2450	2.40	50.9	35	
		60		0.190	13.0	2750	2.70	64.6	39	
4715MS-20T-B40-B00	200	50	130	0.130	15.0	2450	2.40	50.9	35	
		60		0.110	13.0	2750	2.70	63.7	39	
4715MS-22T-B40-B00	220	50	145	0.110	14.0	2450	2.40	53.9	35	
		60		0.100	12.0	2750	2.70	63.7	39	
4715MS-23T-B40-A00	230	50	175	0.120	15.0	2450	2.40	53.9	35	
		60		0.100	13.0	2750	2.70	63.7	39	
4715MS-24T-B40-A00	240	50	140	0.100	13.0	2450	2.40	50.9	35	
		60		0.080	12.0	2750	2.70	58.8	39	

**B30 型スタンダードタイプ Standard Type B30**

型式 Model	定格電圧 Rating Voltage	周波数 Frequency	起動電圧 Starting Voltage	定格電流 Current	定格入力 Input Power	定格回転速度 Speed	最大風量 Max. Air Flow	最大静圧 Max. Static Pressure	騒音 Noise	質量 Mass
	(V)	(Hz)	(V)	(A) <sup>*1</sup>	(W) +10%, -20%	(min <sup>-1</sup> ) <sup>*3</sup>	(m <sup>3</sup> /min) <sup>*3</sup>	(Pa) <sup>*3</sup>	(dB) <sup>*2</sup>	(g)
4715MS-10T-B30-B00	100	50	65	0.190	11.0	2400	2.30	49.9	34	550
		60		0.170	10.0	2600	2.50	50.9	37	
4715MS-12T-B30-A00	115	50	75	0.160	11.0	2400	2.30	49.9	34	
		60		0.140	10.0	2600	2.50	49.9	37	
4715MS-20T-B30-B00	200	50	130	0.090	10.0	2400	2.30	48.0	34	
		60		0.080	10.0	2600	2.50	46.0	37	
4715MS-22T-B30-B00	220	50	145	0.090	11.0	2400	2.30	49.0	34	
		60		0.080	10.0	2600	2.50	47.0	37	
4715MS-23T-B30-A00	230	50	175	0.100	12.0	2400	2.30	49.0	34	
		60		0.080	11.0	2600	2.50	51.9	37	
4715MS-24T-B30-A00	240	50	140	0.090	12.0	2400	2.30	49.0	34	
		60		0.080	11.0	2600	2.50	50.9	37	

**B20 型スタンダードタイプ Standard Type B20**

型式 Model	定格電圧 Rating Voltage	周波数 Frequency	起動電圧 Starting Voltage	定格電流 Current	定格入力 Input Power	定格回転速度 Speed	最大風量 Max. Air Flow	最大静圧 Max. Static Pressure	騒音 Noise	質量 Mass
	(V)	(Hz)	(V)	(A) <sup>*1</sup>	(W) +10%, -20%	(min <sup>-1</sup> ) <sup>*3</sup>	(m <sup>3</sup> /min) <sup>*3</sup>	(Pa) <sup>*3</sup>	(dB) <sup>*2</sup>	(g)
4715MS-10T-B20-B00	100	50	65	0.130	8.0	2100	2.00	35.2	32	550
		60		0.120	8.0	1950	1.90	24.5	30	
4715MS-12T-B20-A00	115	50	75	0.100	7.0	2100	2.00	35.2	32	
		60		0.100	7.0	1950	1.90	24.5	30	
4715MS-20T-B20-B00	200	50	130	0.060	7.0	2100	2.00	32.3	32	
		60		0.060	7.0	1950	1.90	20.5	30	
4715MS-22T-B20-B00	220	50	145	0.060	7.0	2100	2.00	31.3	32	
		60		0.060	7.0	1900	1.90	19.6	30	
4715MS-23T-B20-A00	230	50	175	0.060	7.5	2100	2.00	35.2	32	
		60		0.060	7.5	1900	1.90	21.5	30	
4715MS-24T-B20-A00	240	50	175	0.060	8.0	2100	2.00	38.2	32	
		60		0.060	8.0	1900	1.90	24.5	30	

**B10 型スタンダードタイプ Standard Type B10**

型式 Model	定格電圧 Rating Voltage	周波数 Frequency	起動電圧 Starting Voltage	定格電流 Current	定格入力 Input Power	定格回転速度 Speed	最大風量 Max. Air Flow	最大静圧 Max. Static Pressure	騒音 Noise	質量 Mass
	(V)	(Hz)	(V)	(A) <sup>*1</sup>	(W) +10%, -20%	(min <sup>-1</sup> ) <sup>*3</sup>	(m <sup>3</sup> /min) <sup>*3</sup>	(Pa) <sup>*3</sup>	(dB) <sup>*2</sup>	(g)
4715MS-10T-B10-B00	100	50	65	0.110	7.0	1350	1.30	16.6	27	550
		60		0.100	6.5	1450	1.40	16.6	28	
4715MS-12T-B10-A00	115	50	75	0.090	6.0	1350	1.30	15.6	27	
		60		0.080	5.5	1450	1.40	16.6	28	
4715MS-20T-B10-B00	200	50	130	0.055	6.0	1350	1.30	14.7	27	
		60		0.050	5.5	1450	1.40	14.7	28	
4715MS-22T-B10-B00	220	50	145	0.050	6.0	1350	1.30	14.7	27	
		60		0.040	5.5	1450	1.40	14.7	28	
4715MS-23T-B10-A00	230	50	175	0.050	6.5	1350	1.30	14.7	27	
		60		0.045	6.0	1450	1.40	14.7	28	
4715MS-24T-B10-A00	240	50	175	0.050	6.5	1350	1.30	15.6	27	
		60		0.045	6.0	1450	1.40	16.6	28	

回転方向：ラベルから見て反時計方向  
風吹き出し方向：ラベル側

Rotation: Counterclockwise as seen from the label side.  
Airflow Outlet: Label side

\*1: Maximum Values in Free Air  
\*2: Average Values in Free Air  
\*3: Minimum Values in Free Air