

产品说明 General Data

耐压Dielectric withstand voltage: AC 1500V (50/60Hz) one minute
 安全保护Protection: Impedance protection or thermal protection
 工作温度Operating Temperature: Ball bearing: -20°C~+75°C
 Sleeve bearing: -10°C~+70°C

使用寿命Life Expectancy: Ball bearing: over 40000 hr. (At 40°C)
 Sleeve bearing: over 15000 hr. (At 40°C)

安规认证Safety: UL>CUL>TUV>CE>CCC

重量Weight: 268g
 尺寸图 Outline

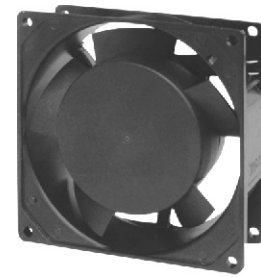

风量Airflow: 37 ~ 58m³/hr 22~34CFM

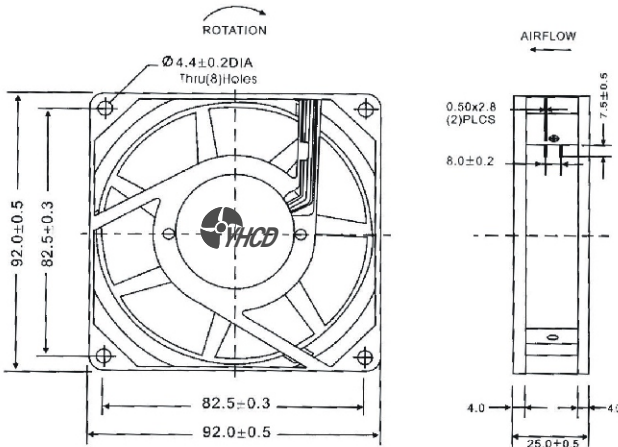

材料 Material

外框 Frame: Aluminum alloy
 风叶 Impeller: Plastic 94V-0 PBT covering glass fiber
 马达 Motor: Shaded pole induction motor
 连接方式 Connection: Lead wire or terminal type

开孔尺寸 Panel Cut-outs

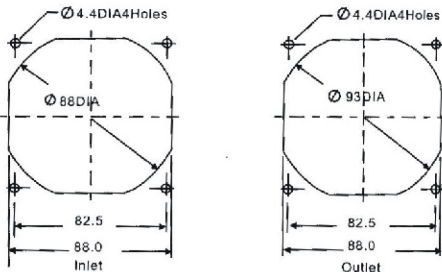

曲线图 Characteristic Curves

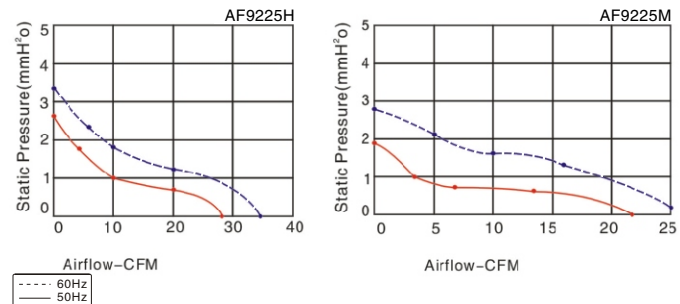

技术参数 Specifications

Model (型号)	Bearing system (轴承型式)	Voltage VAC (电压)	Freq. Hz (频率)	Current A (电流)	Power W (功率)	Speed RPM (转速)	Noise dBA (噪音)	Air Flow(风量)		Phase (相数)	Capacitor (电容)
								M3/hr	CFM		
AF9225HA,S	Sleeve	100-120	50/60	0.16	14	2300/2800	30/40	47/58	28/34	1	/
AF9225HA ₂ S		200-240	50/60	0.08	14	2300/2800	30/40	47/58	28/34	1	/
AF9225HA,B	Ball	100-120	50/60	0.16	14	2300/2800	30/40	47/58	28/34	1	/
AF9225HA ₂ B		200-240	50/60	0.08	14	2300/2800	30/40	47/58	28/34	1	/
AF9225MA,S	Sleeve	100-120	50/60	0.14	13	1800/2300	28/35	37/45	22/26	1	/
AF9225MA ₂ S		200-240	50/60	0.07	13	1800/2300	28/35	37/45	22/26	1	/
AF9225MA,B	Ball	100-120	50/60	0.14	13	1800/2300	28/35	37/45	22/26	1	/
AF9225MA ₂ B		200-240	50/60	0.07	13	1800/2300	28/35	37/45	22/26	1	/