

## 产品说明 General Data

耐压Dielectric withstand voltage: AC 1500V (50/60Hz) one minute  
 安全保护Protection: Impedance protection or thermal protection  
 工作温度Operating Temperature: Ball bearing: -20°C~+75°C  
 使用寿命Life Expectancy: Ball bearing: over 50000 hr. (At 40°C)  
 安规认证Safety: UL>CUL>TUV>CE>CCC  
 重量Weight: 1600g



风量Airflow: 612 ~ 790m<sup>3</sup>/hr 360~465CFM

## 尺寸图 Outline

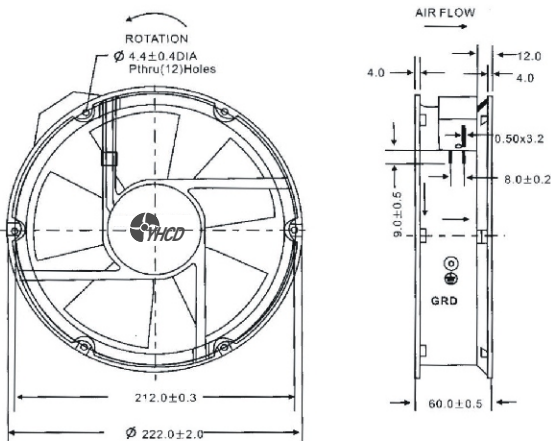

## 材料 Material

外框 Frame: Aluminum alloy  
 风叶 Impeller: Plastic 94V-0 PBT covering glass fiber  
 马达 Motor: Shaded pole and capacitor-run induction motor  
 连接方式 Connection: Lead wire or terminal type

## 开孔尺寸 Panel Cut-outs

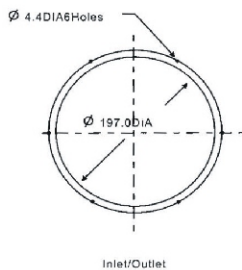

## 曲线图 Characteristic Curves

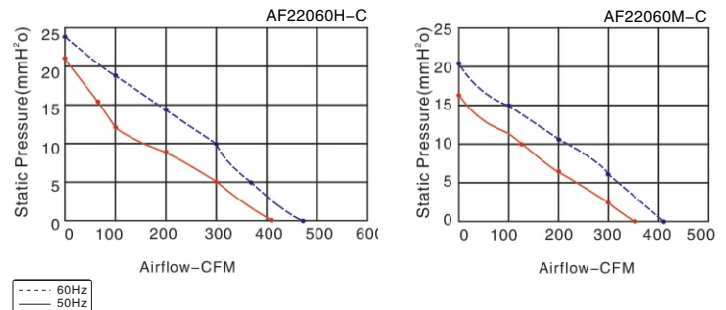

## 技术参数 Specifications

Model (型号)	Bearing system (轴承型式)	Voltage VAC (电压)	Freq. Hz (频率)	Current A (电流)	Power W (功率)	Speed RPM (转速)	Noise dBA (噪音)	Air Flow( 风量 )		Phase (相数)	Capacitor (电容)
								M <sup>3</sup> /hr	CFM		
AF22060HA,B-C	Ball	100-120	50/60	0.42	42	2600/2900	62/68	690/790	406/465	1	3.3uf/630v
AF22060HA <sub>2</sub> ,B-C	Ball	200-240	50/60	0.2	40	2600/2900	62/68	690/790	406/465	1	1.5uf/630v
AF22060MA <sub>3</sub> ,B	Ball	380-420	50/60	0.32	42	2300/2600	56/62	612/690	360/406	3	1uf/630v
AF22060MA <sub>2</sub> ,B	Ball	380-420	50/60	0.6	47	2300/2600	56/62	612/690	360/406	1	/