

*New*

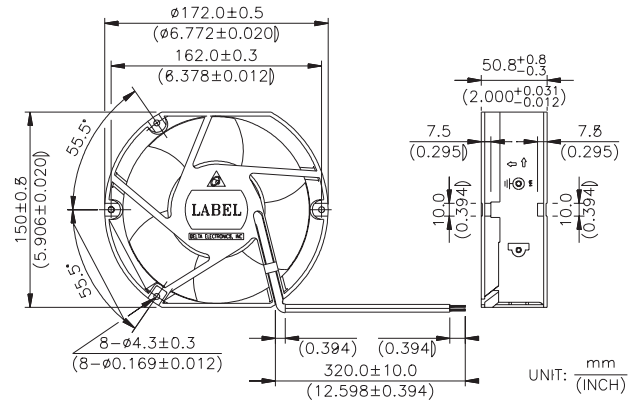

### ■ DIMENSIONS DRAWING



- \* Bearing Type  
Ball Bearings
- \* Material  
Impeller : Plastic (UL 94V-0)  
Frame: Die-Cast Aluminum
- \* Lead Wires :  
UL 1007 AWG #24 OR Equivalent  
Red Wire Positive (+)  
Black Wire Negative (-)
- \* Weight : 800g (28.22 oz)

### ■ P & Q CURVE (AT RATED VOLTAGE)

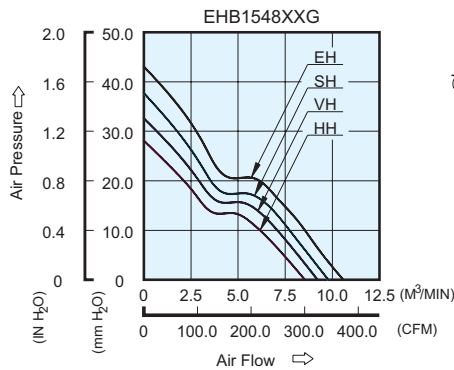

### ■ MOUNTING PANEL CUTOUT

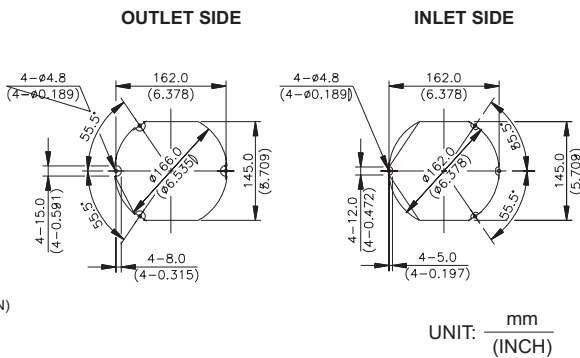

MODEL		Rated Voltage	Operating Voltage Range	Rated Current	Rated Input Power	Speed	Maximum Air Flow		Maximum Air Pressure		Noise
PART NO.	FUNCTION	VDC	VDC	Amp	Watt	R.P.M.	m <sup>3</sup> /min	CFM	mmH <sub>2</sub> O	IN H <sub>2</sub> O	dB-A
EHB1548HHG	-R00 / -F00	48	32.0 to 80.0	0.61	29.28	4300	8.565	302.47	28.33	1.115	62.5
EHB1548VHG	-R00 / -F00	48	32.0 to 80.0	0.72	34.56	4600	9.235	326.13	32.87	1.294	64.5
EHB1548SHG	-R00 / -F00	48	32.0 to 80.0	0.88	42.24	4900	9.828	347.08	37.89	1.492	66.5
EHB1548EHG	-R00 / -F00	48	32.0 to 80.0	1.20	57.60	5200	10.608	374.62	43.27	1.703	68.5

\* Function type is optional.  
 \* The max. air flow and the speed are measured in free air ; max. air pressure is measured at zero air flow.  
 \* Noise is measured in anechoic chamber in free air, one meter from intake side.  
 \* All readings are typical values at rated voltage.  
 \* Specifications are subject to change without notice.

**北京永宏诚大机电设备有限责任公司** 电话:86-10-66131492  
 传真:86-10-66162242