

◀ **70X70X15mm Series** ▶

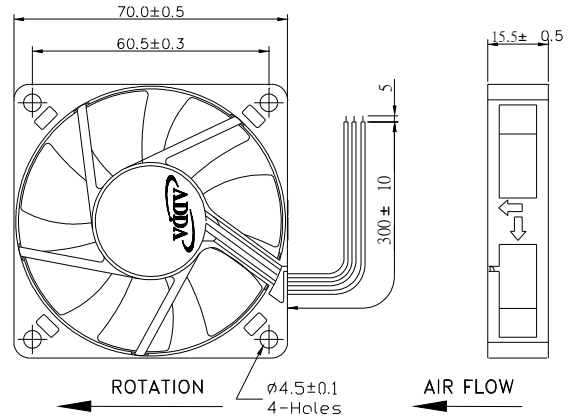

Spot cooling, also suitable for small space requirements, laptops PC and notebook, etc.,

External Dimensions



Frame: Plastic(UL:94v-0)
Impeller: Plastic(UL:94v-0)
Bearing: Hypro bearing
Lead wire: UL1007AWG24
OPERATING TEMP*: -10C~70C
VOLTAGE AVAILABLE: 12V
*: -10C~60C for fans with sleeve/ball combination bearings.

Specifications(Nominal)

*: Noise is measured at the distance of one(1) meter from the axis of intake.

Frame size (mm)	Model No.	Bearing System Type	Rated Voltage (v)	Rated Current (A)	Rated Power (W)	Rated Speed (rpm)	Bearing type: =Ball =Sleeve =1B1S =Hypro bearing				Weight (g)	
							Maximum AirFlow (CMM)	Maximum Pressure (InAq)	Maximum Pressure (mmAq)	Noise Level (dB/A)		
70X70X15	AD0712DB-D70(T)		12	0.11	1.32	2500	0.561	19.90	0.076	1.91	26.3	61
	AD0712LB-D70(T)		12	0.14	1.68	3000	0.701	24.88	0.107	2.68	30.1	
	AD0712MB-D70(T)		12	0.18	2.16	3500	0.823	29.23	0.146	3.64	34.5	
	AD0712HB-D70(T)		12	0.27	3.24	4000	0.948	33.65	0.186	4.66	38.4	

Specifications subject to change without notice.

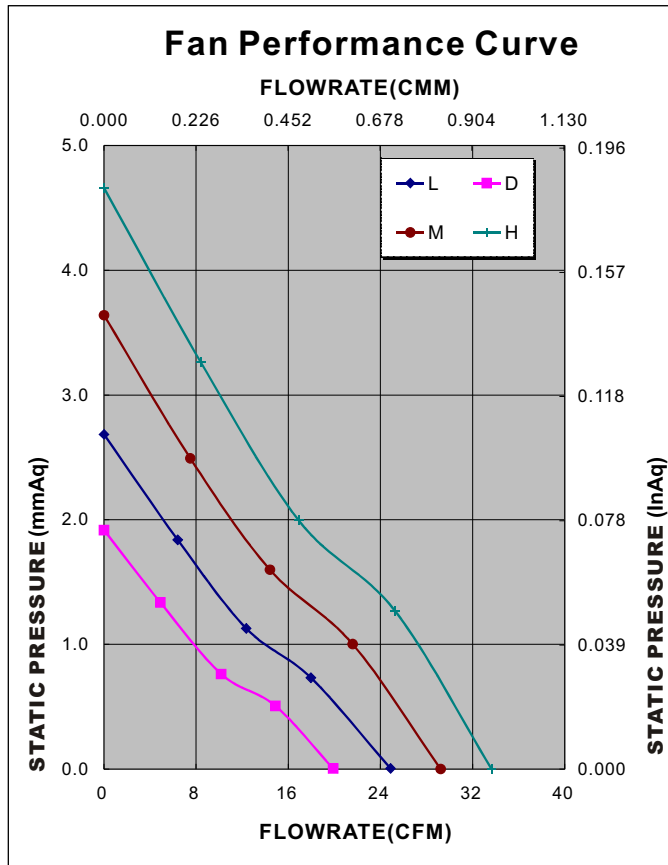

*Motor protective circuit and third lead wire functions

0	1	2	3	4	6	7	8	9	A	B
✓					✓					

*Safety approvals

									✓	

